

Platzbedarf Kühlaggregat 1000 x 1000 mm  
 Abstand zu Wand beachten:  
 Freie Luftzirkulation erforderlich

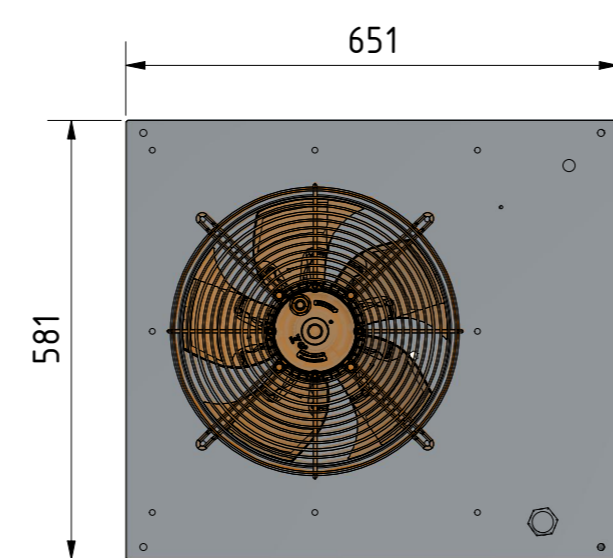

maximaler Abstand  
 9 m

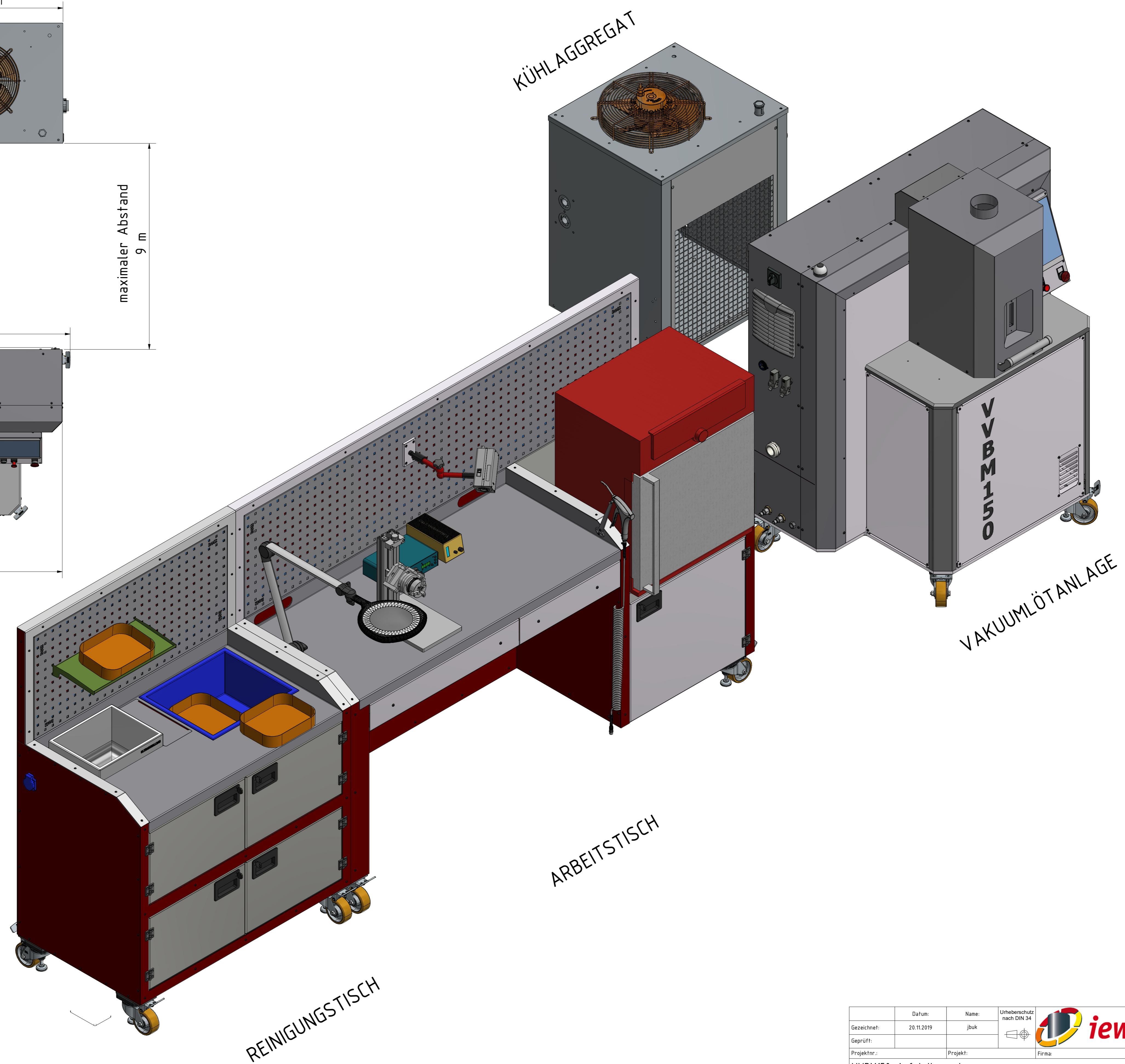
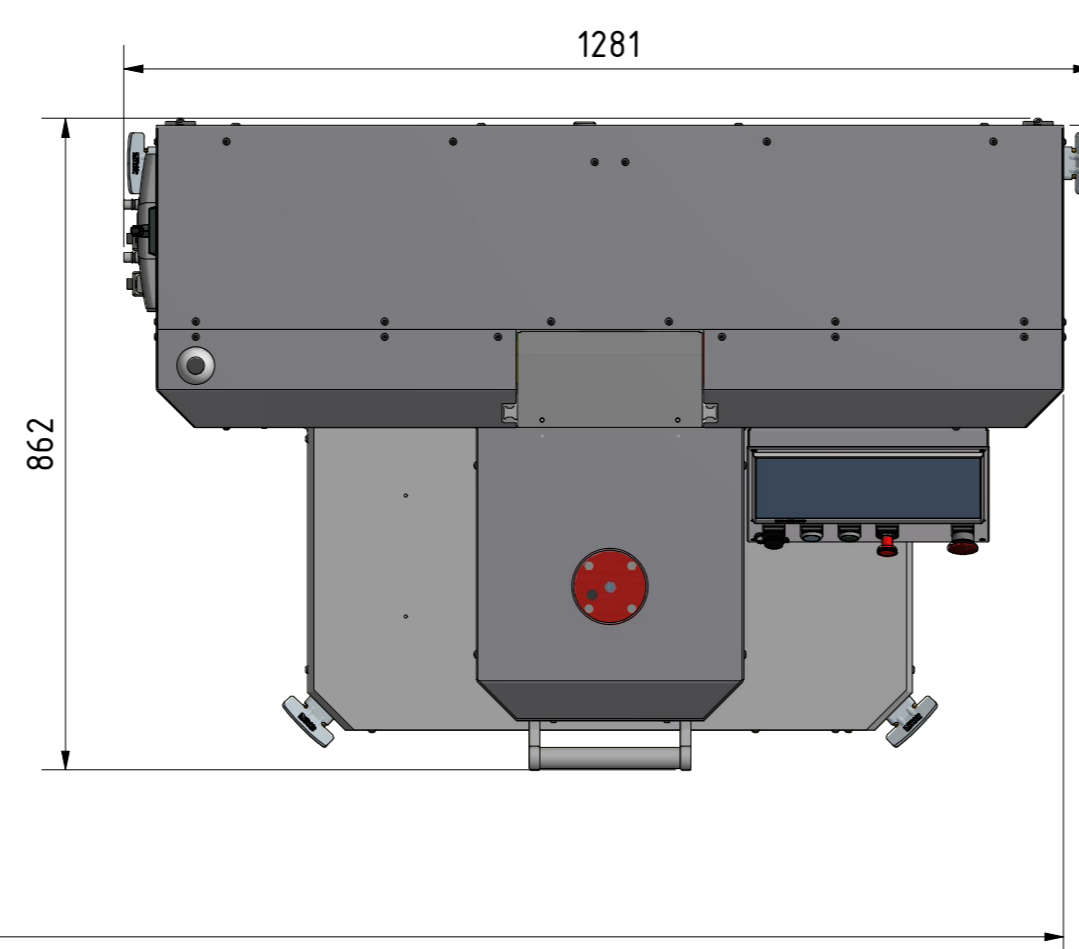
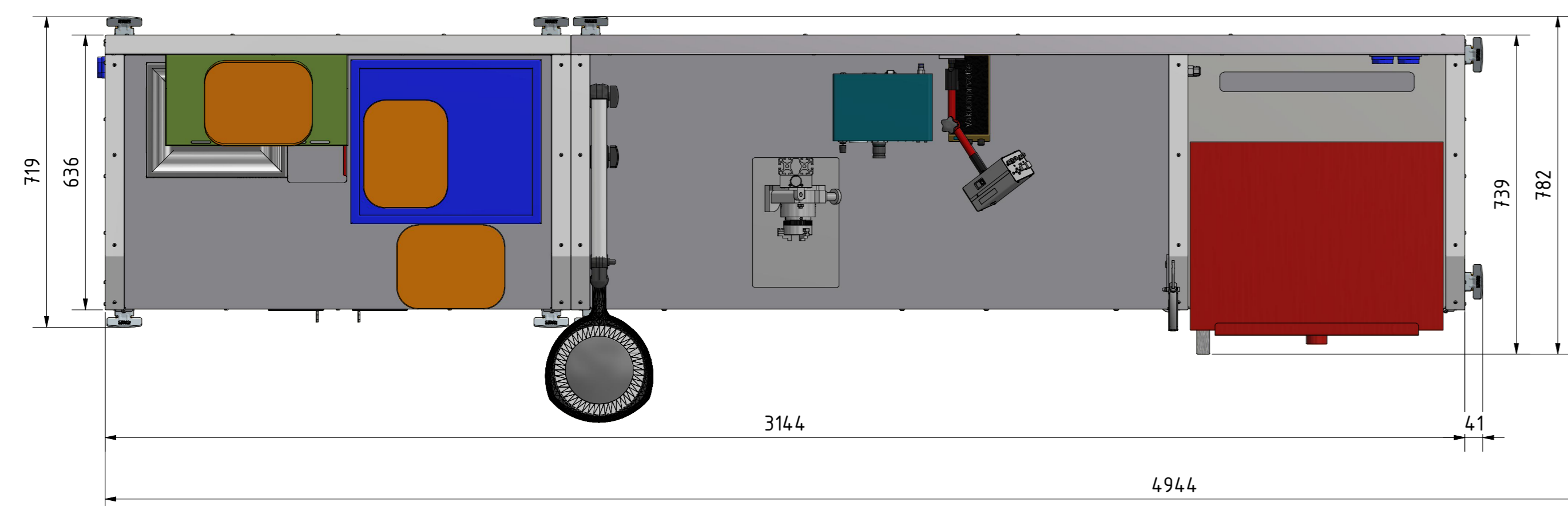

Datum:	29.11.2019	Name:	jsk	Ufferschutz:	nach DIN 94	iew	iew Industrietechnik GmbH Hornstrasse 19 23566 Elmshorn Tel: +49 2352 481 100-0 Fax: +49 2352 481 100-21 office@iew.de www.iew.de	
Projekt:		Projekt:		Form:		Anzahl:		
VVB150_Aufstellungsplan							Zeilengröße:	-
LAYOUT							Maßstab:	1:10
							Blattgröße:	A0
							Revision:	

Datum: C:\Users\jovani\OneDrive\Documents\PROJEKTE\VVB150\PRESENTATION\VVB150\_Aufstellungsplan\_VVB150-000001.dwg  
 Allgemein toleranz ISO 2768 - m1

